

CCF

part of the Travis Perkins Group

GLASS PARTITIONING SOLUTIONS

fastglaze
GLASS PARTITIONING **IN JUST 5 DAYS**

CCF know how

www.ccfstd.co.uk

**INSULATION • DRYWALL • CEILINGS
PARTITIONING • FLOORING • FIRE PROTECTION
INSULATION • DRYWALL • CEILINGS**

What is the CCF Fastglaze offer?

Up to 40lm of single glazed Aluminium track*, in either Silver RAL 9006 or White RAL 9010, with a maximum of 2 frameless glass doors supplied and installed within 5 working days, from receipt of confirmed written order and subject to site being ready.

How It Works – 5 Days

- Day 1 - Place order with any CCF Partitioning branch before 11am*
- Day 2 - Tracks delivered to site and installed**
- Day 3 - Site survey carried out for glass/glass doors
- Day 4 & 5 - Glass/glass doors and ironmongery installed
- Day 5 - Manifestation D.D.A. dots applied

Benefits

- System installed by fully trained installation teams
- Method Statements, Risk Assessments and COSHH data supplied with every project
- Offer available for all UK Mainland areas

Conditions

- Hoisting charges will be applicable to all floors above 2nd floor level
- Price on Application – Service will begin upon acceptance of customer order

*See list of participating branches on page 5.

**Aluminium track can be purchased and installed by customer if preferred.

***Vertical silicone joints available as an option at no extra cost if preferred.

Standard Specification Offer

- 10mm Toughened Clear Glass up to 2500mm Height
- 12mm Toughened Clear Glass up to 3000mm Height
- 12.8mm Acoustic Laminated Clear Glass up to 3000mm Height
- 15mm Toughened Clear Glass up to 3300mm Height
- 12mm Toughened Glass Full Height Max 2700mm
- Dorma BTS75 Floor Spring, 600mm D Handles, Dorma PT10/PT20 Patch Fittings all in Satin Stainless Steel Finish
- 12mm Toughened Clear Glass Sliding Door using Trojan 120 Sliding Mechanism Full Height
- Vertical I-Line Glazed Joints***
- 50mm Dot/Square Opal Frost Type Manifestation



Trojan 120 Sliding Doors

The Trojan 120 is a low friction, easy slide door system which is suitable in low headroom applications, is very quiet in operation and has adjustable strength end stop.

Dumbard Fitting

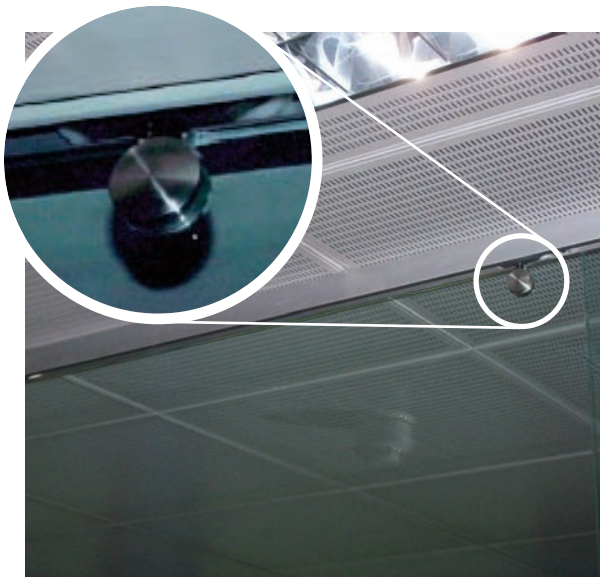

POL-I-PLAS I-Line Dry Glazed Joints

Using POL-I-PLAS I-Line dry glazed joints provides exceptional transparency, and with a glass joint space of only 2.4mm, a much more minimalist look is achieved.

I-Line Dry Glazed Joint Profiles

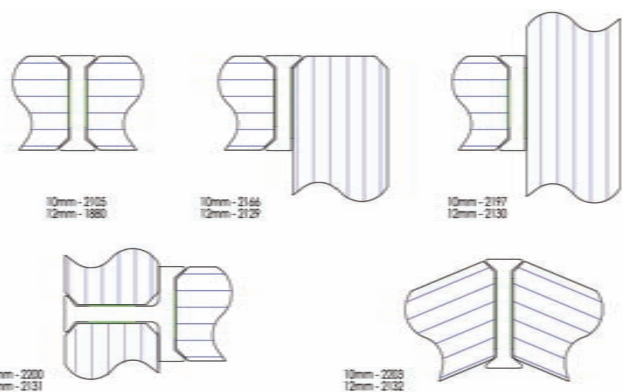
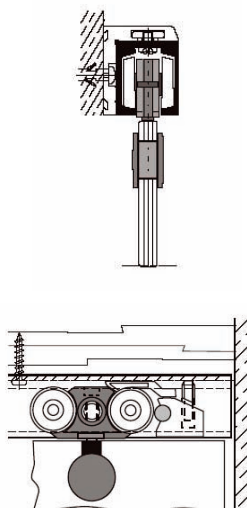
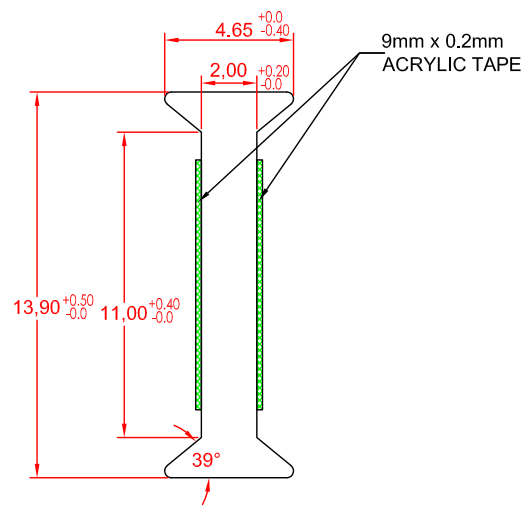

Components

FastGlaze uses Aluminium frameless single glazed components which are available in a choice of two colours, Silver 9006 or White RAL9010, with “infill” sections being used in either Headtrack or Wall Abutments at door openings. The “Drywall Pocket Adaptor” is used to integrate with 75mm wide plasterboard walls.



List of Major Fastglaze Components
Description
Aluminium Head Track 32mm – 3600mm RAL9006
Aluminium Head Track 32mm – 3600mm RAL9010
Aluminium Wall Abutment 32mm – 3000mm RAL9006
Aluminium Wall Abutment 32mm – 3000mm RAL9010
Aluminium Head Track Infill – 3000mm RAL9006
Aluminium Head Track Infill – 3000mm RAL9010
Aluminium Head Track Infill – 1000mm RAL9006
Aluminium Head Track Infill – 1000mm RAL9010
Aluminium Base Track 2 Park – 3000mm RAL 9006
Aluminium Base Track 2 Park – 3000mm RAL 9006
Aluminium 75mm Drywall Pocket Adaptor – 3000mm RAL9006
Aluminium 75mm Drywall Pocket Adaptor – 3000mm RAL 9010
Aluminium Glass Door Pivot Block
Glazing Wedge 100mm roll – for 10mm glass
Glazing Wedge 100mm roll – for 12mm glass
I-line PETg DryGlaze Joint Ref 2105 In-Line 2 Way (10mm) 3000mm
I-line PETg DrtGlaze Joint Ref 1880 In-Line 2 Way (12mm) 3000mm

CCF Nationwide Branch Network

North

♥ Carlisle	Tel: 01228 672257	Fax: 01228 674728
♥ Doncaster	Tel: 01302 786043	Fax: 01302 784963
♥ East Kilbride	Tel: 01355 244400	Fax: 01355 246464
♥ Edinburgh	Tel: 01314 404023	Fax: 01314 403652
♥ Glasgow	Tel: 0141 445 2557	Fax: 0141 445 5660
♥ Leeds	Tel: 08700 979797	Fax: 08707 550671
♥ Liverpool	Tel: 0151 933 8444	Fax: 0151 933 7998
♥ Manchester	Tel: 0161 877 4088	Fax: 0161 877 0688
♥ Newcastle	Tel: 0191 491 4992	Fax: 0191 491 3896
♥ Nottingham	Tel: 01773 711404	Fax: 01773 711944

Midlands & South West

♥ Birmingham	Tel: 0121 525 8877	Fax: 0121 500 5594
♥ Bristol	Tel: 0117 982 2613	Fax: 0117 982 2619
♥ Cannock	Tel: 01543 686998	Fax: 01543 677283
♥ Cardiff	Tel: 029 2076 3311	Fax: 029 2075 5910
♥ Christchurch	Tel: 01202 496666	Fax: 01202 496644
♥ Exeter	Tel: 01392 362128	Fax: 01392 362125
♥ Portsmouth	Tel: 023 9241 3770	Fax: 023 9241 3790
♥ Reading	Tel: 0118 949 2540	Fax: 0118 935 2439
♥ Southampton	Tel: 01489 785155	Fax: 01489 787910
♥ Swindon	Tel: 01793 497580	Fax: 01793 611308

South East

♥ Ashford	Tel: 01233 611135	Fax: 01233 611143
♥ Basildon	Tel: 01268 293323	Fax: 01268 527070
♥ Croydon	Tel: 020 8665 6113	Fax: 020 8683 0256
♥ East London	Tel: 020 7540 5050	Fax: 020 7476 9955
♥ Heathrow	Tel: 020 8893 5353	Fax: 020 8893 5244
♥ Park Royal	Tel: 020 8965 4222	Fax: 020 8965 4777
♥ Peterborough	Tel: 01733 551 333	Fax: 01733 311921
♥ Stevenage	Tel: 01438 740055	Fax: 01438 741600
♥ Thetford	Tel: 01842 766316	Fax: 01842 753728
♥ West London	Tel: 020 8810 5533	Fax: 020 8566 7755

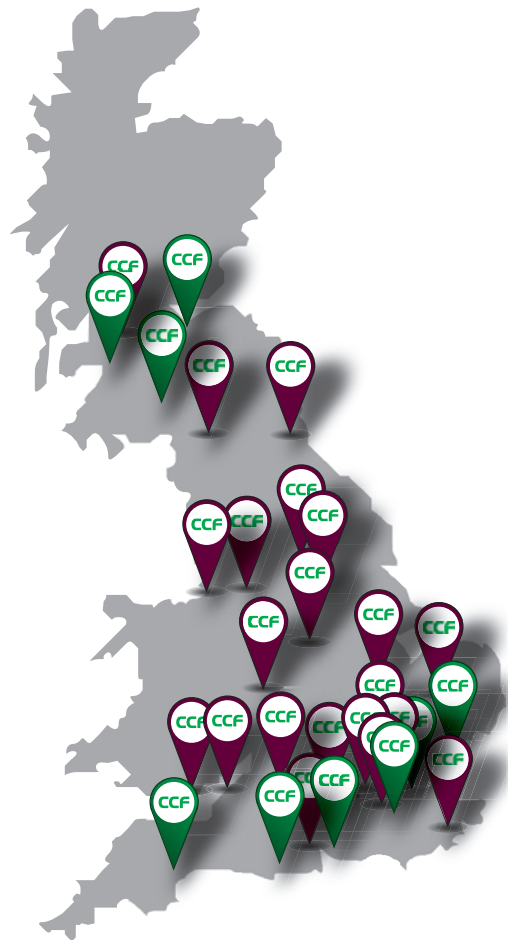

Key



CCF Branch



CCF Branches Supplying Fastglaze

CCF offer a complete service to the interiors building industry specialising in ceilings, drywall, flooring, insulation, partitioning and fire protection. We hold comprehensive stocks of quality products and provide complete solutions for interior specialists, contractors and builders.



Head Office

1-3 Gillette Way
Off Manor Farm Road
Reading
Berkshire RG2 0BS
T. 0118 949 1092
F. 0118 926 8831
www.ccfld.co.uk

The information (including prices) contained in this publication is believed to be correct and complete at the time of printing. Due to limitations in the printing process images may not be representative of their true colours. Stock may vary from branch to branch and is subject to availability. All photographs are as a guide only and do not necessarily represent the products available. CCF reserves the right to change product details without prior notice. E&OE. January 2011. JB59666 07/11.